

Recessed Gripper Bracket Suspension Instruction

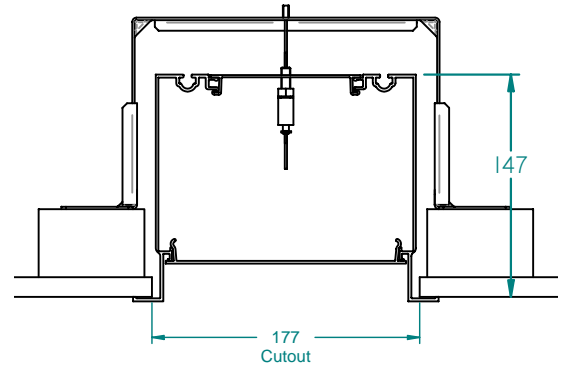

170RB

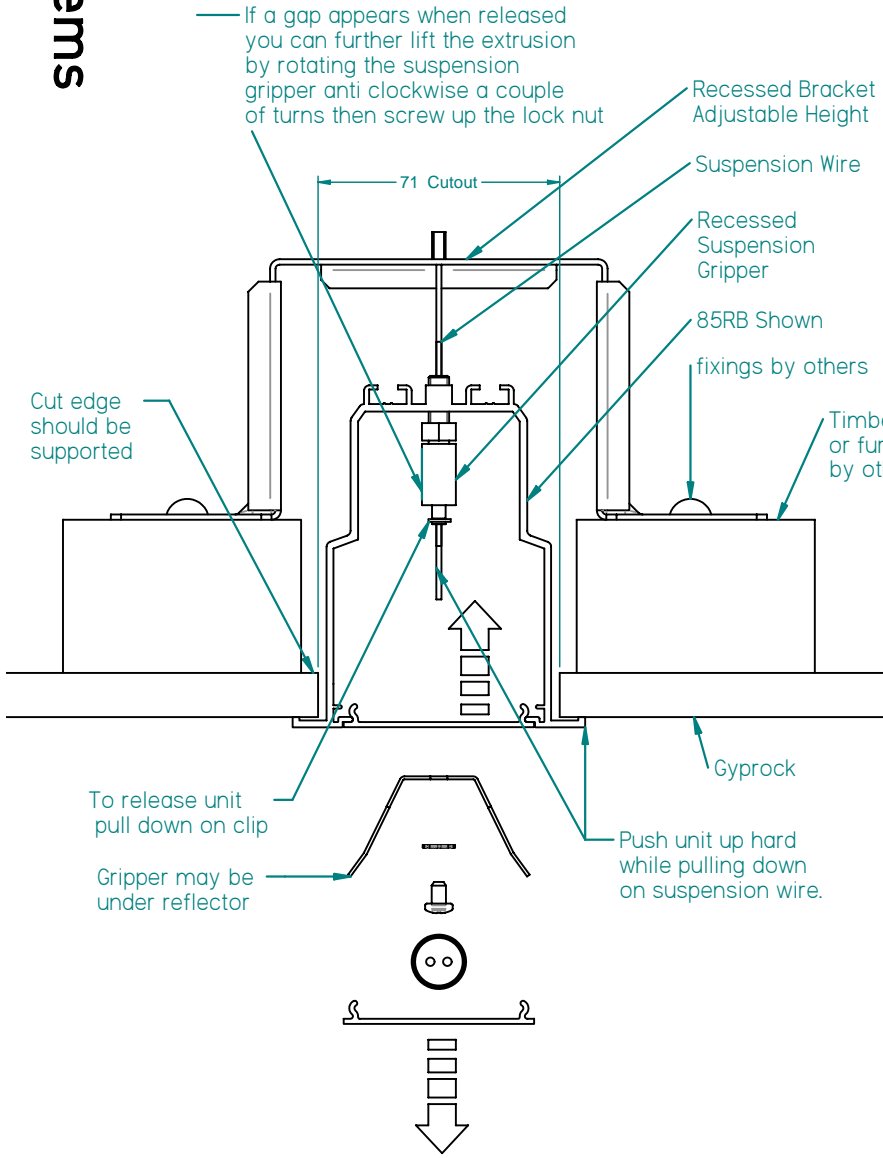
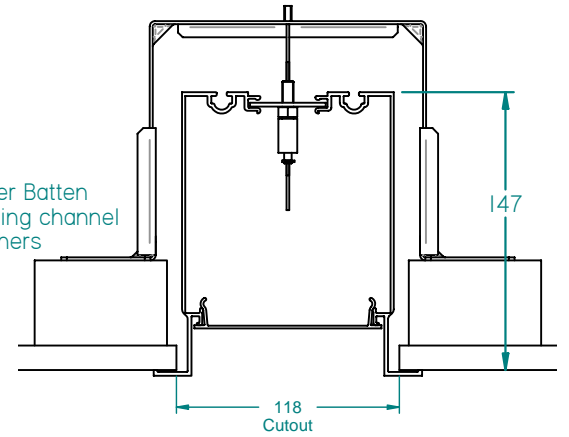

110RB (170RB body)

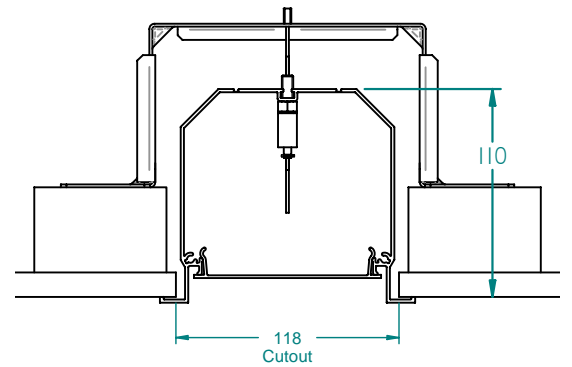

110RB

Important

Choosing an appropriate fixing to suit the mounting surface is the responsibility of the installer.

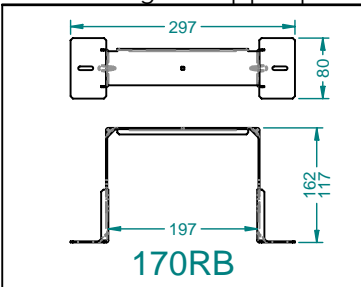
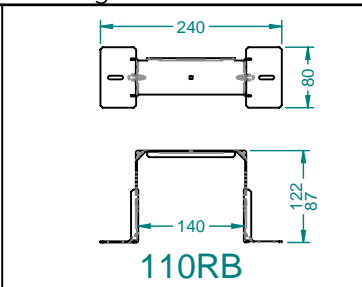
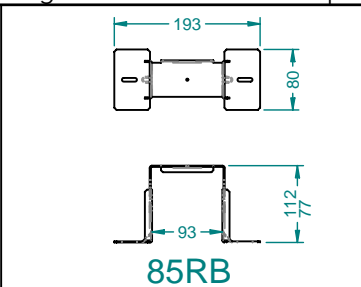
 <p>170RB</p>	 <p>110RB</p>	 <p>85RB</p>	<p>Note: Extrusion body drilled & tapped with M6 thread in nominal suspension locations. These may need to be relocated onsite by installer to suit onsite requirements. Where possible advise Klik at time of order of suspension location requirements.</p>
---	--	--	---